

AG DIM.				
	2 POLE	4 POLE	6 POLE	8 POLE
1/2 HP	10.31	10.31		
1 HP	11.81	11.81		
1.5 HP	12.31	12.31		
2 HP	12.31	12.81		
3 HP	12.81			

REVISIONS			
REV	DESCRIPTION	BY	DATE

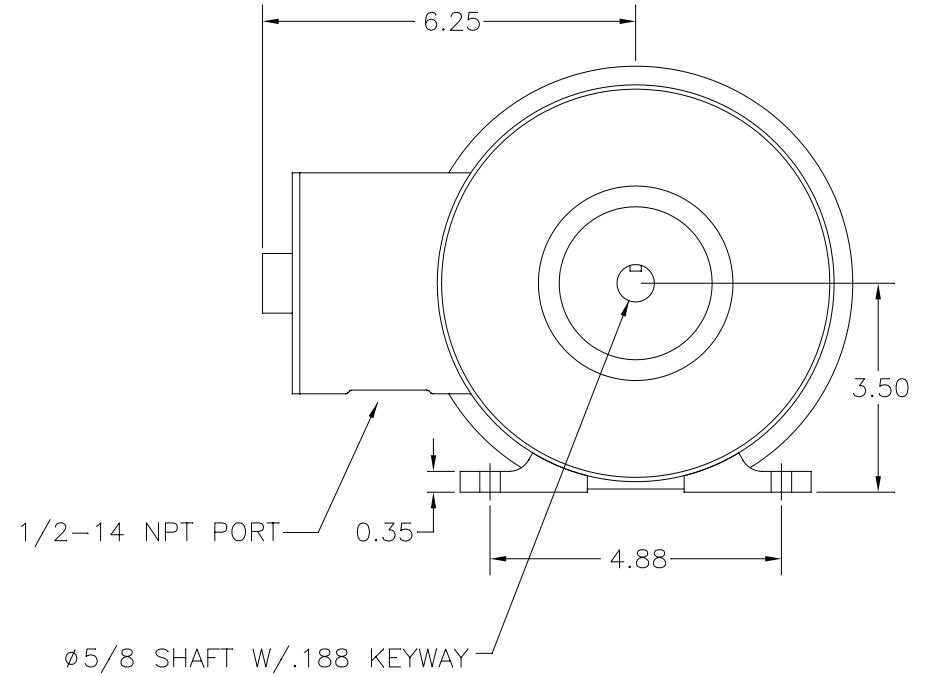
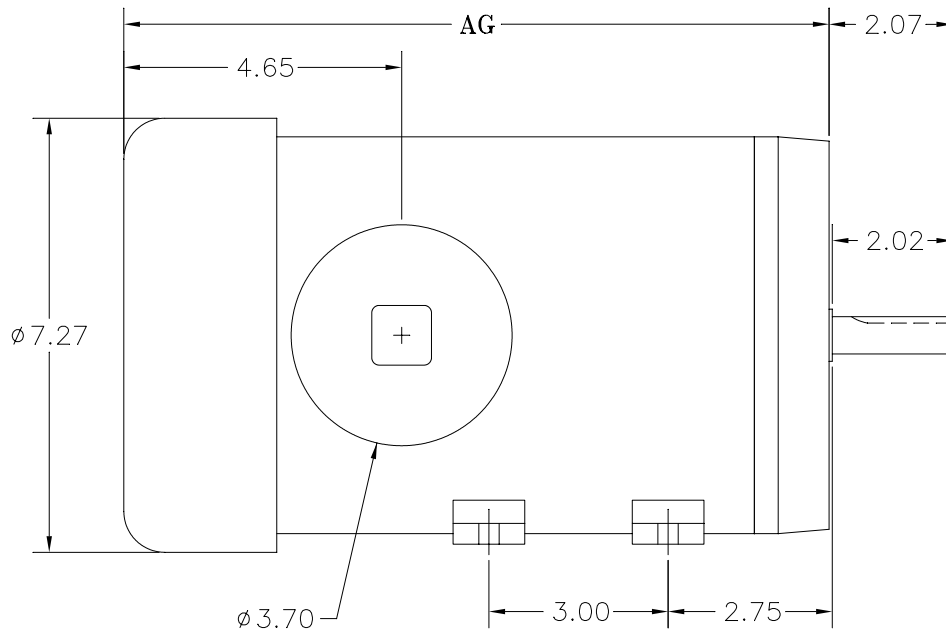

1. ALLOW 1" CLEARANCE BEYOND FAN SHROUD FOR AIR FLOW

NOTES:

DO NOT SCALE DRAWING	MATERIAL: T304 EXTERIOR 17-4 H1150 SHAFT	STAINLESS MOTORS INC.
UNLESS OTHERWISE SPECIFIED	FINISH: #2B AS CAST FEET	
DIMENSIONS ARE IN INCHES	GENERAL TOLERANCES: .X = ±.015 .XX = ±.010 .XXX = ±.005	DRAWN GP
DIMENSIONS AND SURFACE TEXTURE DESIGNATIONS APPLY PRIOR TO FINISH	FRACTIONAL = ±1/64 ANGULAR = ±1/2°	CHECK
DEBURR AND BREAK ALL SHARP EDGES .005-.015	REFERENCE DRAWING:	ENG. JO
	DRWG. NO. DRAFTING\MOTORS\STANDARDIZED DRAWINGS\FOOD\56\56	DATE 4/21/03
		56 FRAME FOOT MOUNT TEFC, THRU FOOT