

AG DIM.

	2 POLE	4 POLE	6 POLE	8 POLE
1/2 HP	11.31	11.31	11.31	12.31
1 HP	11.81	11.81	12.81	
1.5 HP	12.31	12.31		
2 HP	12.81	12.81		
3 HP	12.81			

REVISIONS

REV	DESCRIPTION	BY	DATE

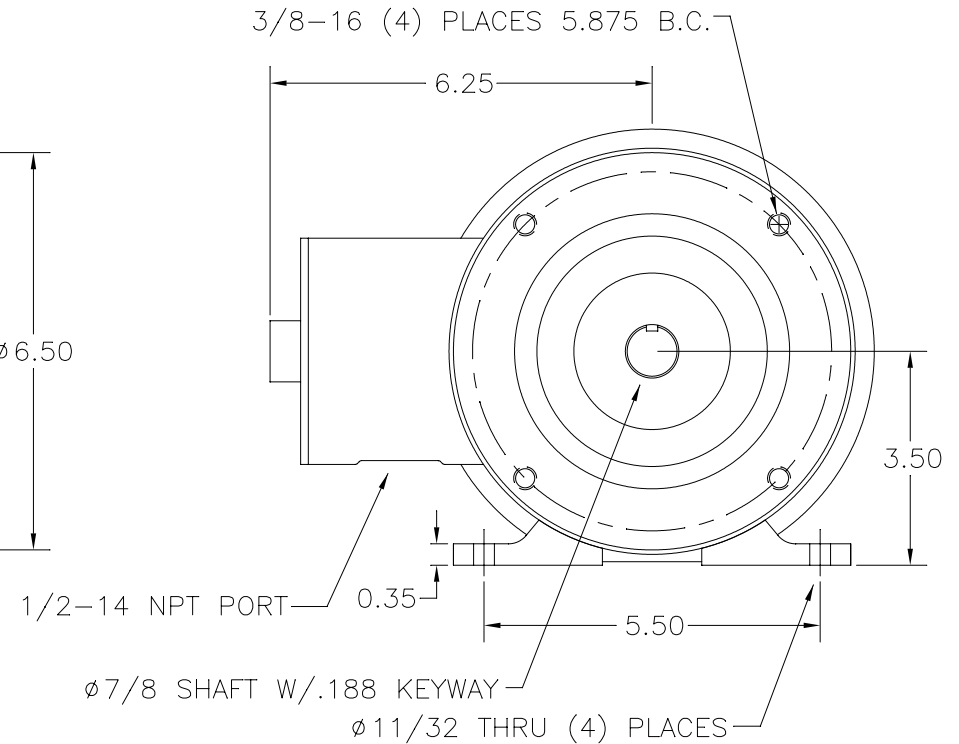
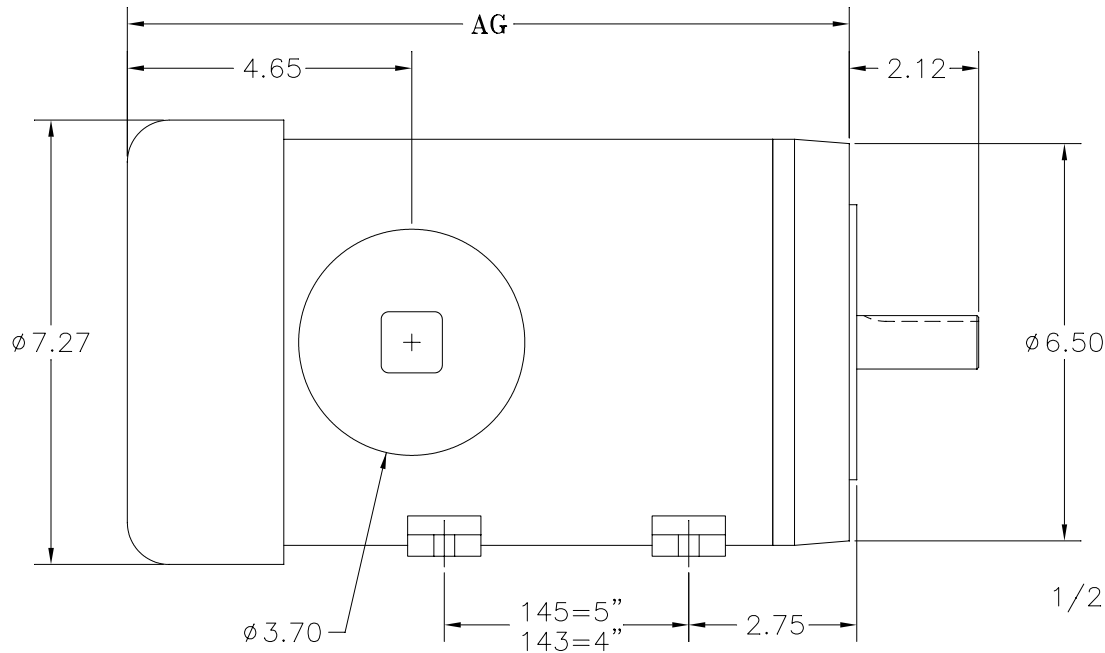

- 3. ALLOW 1" CLEARANCE BEYOND FAN SHROUD FOR AIR FLOW
- 2. FOOTLESS DIMS SAME
- 1. THROUGH HOLE FOOT SHOWN, BLIND TAPPED FOOT AVAILABLE WITH 5/16-18 X .450 DP.

NOTES:

DO NOT SCALE DRAWING	MATERIAL: T304 EXTERIOR 17-4 H1150 SHAFT	<b>STAINLESS MOTORS INC.</b>
UNLESS OTHERWISE SPECIFIED	FINISH: #4 LINE POLISHED SHROUD	
DIMENSIONS ARE IN INCHES	GENERAL TOLERANCES: .X = ±.015 .XX = ±.010 .XXX = ±.005	DRAWN GP CHECK ENG. JO DATE 4/21/03
DIMENSIONS AND SURFACE TEXTURE DESIGNATIONS APPLY PRIOR TO FINISH	FRACTIONAL = ±1/64 ANGULAR = ±1/2°	140TC FRAME C FACE MOUNT TEFC, THRU FOOT
DEBURR AND BREAK ALL SHARP EDGES .005-.015	REFERENCE DRAWING:	
	DRWG. NO. DRAFTING\MOTORS\STANDARDIZED DRAWINGS\PHARM\140\140TC	