

AG DIM.				
	2 POLE	4 POLE	6 POLE	8 POLE
1/2 HP	10.08	10.08	10.08	11.08
1 HP	10.58	10.58	11.58	
1.5 HP	11.08	11.08		
2 HP	11.58	11.58		
3 HP	11.58			

REVISIONS			
REV	DESCRIPTION	BY	DATE

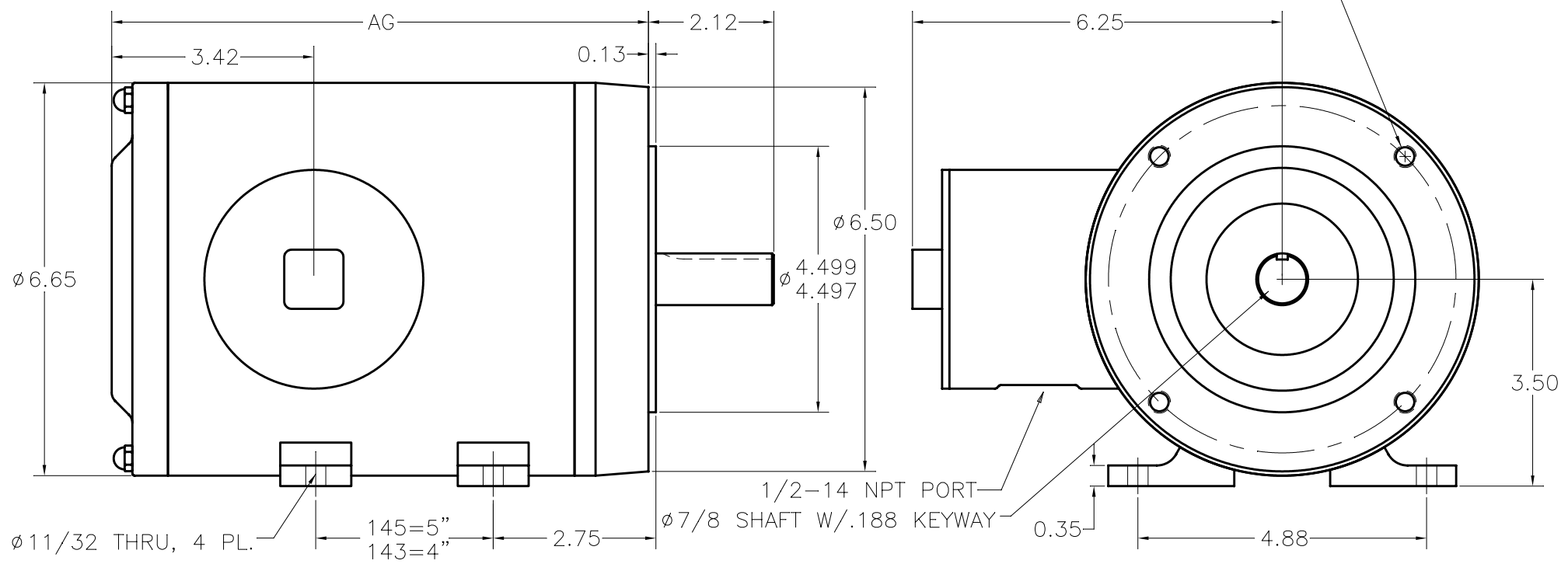

2. FOOTLESS DIMS SAME  
 1. THROUGH HOLE FOOT SHOWN, BLIND TAPPED FOOT  
 AVAILABLE WITH 5/16-18 X .450 DP.

NOTES:

DO NOT SCALE DRAWING	MATERIAL: T304 EXTERIOR 17-4 H1150 SHAFT	<b>STAINLESS MOTORS INC.</b>
UNLESS OTHERWISE SPECIFIED	FINISH: #4 LINE POLISHED SHROUD	
DIMENSIONS ARE IN INCHES	GENERAL TOLERANCES: .X = ±.015 .XX = ±.010 .XXX = ±.005	DRAWN MFG
DIMENSIONS AND SURFACE TEXTURE DESIGNATIONS APPLY PRIOR TO FINISH	FRACTIONAL = ±1/64 ANGULAR = ±1/2°	CHECK
DEBURR AND BREAK ALL SHARP EDGES .005-.015	REFERENCE DRAWING:	ENG. JO
	DRWG. NO. F:\DRAFTING\MOTORS\STANDARDIZED DRAWINGS\PHARM\140\140TC-TENV	DATE 07/06/05
		143TC/145TC FRAME C FACE MOUNT TENV, THRU FOOT